

Description

The 501A rotary drum pump is suitable for the transfer of oil, diesel and petrol from 60L and 205L drums and bulk tanks. The Gladiator 501A rotary drum pumps vanes make it also suitable for the transfer of diesel fuel, unleaded and leaded petrol. The Gladiator 501A comes complete with 2.2m of anti static fuel hose, spout, spout holster and 2" BSP bung adaptor & delivers approximately 18L/min or 0.26L per rotation when pumping diesel fuel.

Specifications

Uses	Diesel, petrols, kerosene, lube oil & machine oil
Discharge Quantity	Approximately 70 turns / 18L/min
Materials	Body hardened aluminum alloy; Handle - aluminum die cast; Seal - Buna N; Hose - anti static fuel hose
Weight/Length	3.6kg/1,300mm (4.3ft)
Size	Suction Tube: 31.8mm (1¼") OD Delivery Hose: 19.05mm (¾") ID x 2.2m

Assembly Instructions

Mount handle assembly (501A-9 & 501A-10) to the pump body (501A-1) with the aid of bolt (501A-18). Connect the outlet tube (501A-12) & the bung (501A-15) and then screw suction tube (501A-16) together with adaptor (501A-25) into the inlet of pump body. When assembling pump & tubes, please ensure that all threads are completely airtight (use thread tape) otherwise the pump will not prime. Test prime by putting your hand over the bottom of the pump body inlet hole, turn handle in a clockwise direction. If you feel a strong suction on the palm of your hand the pump is operating correctly and is now ready to mount into the drum. If not, add a few drops of oil through the inlet hole and turn handle to lubricate internals.

If pumping fuels and the pump does not prime, lubricate pump body with some oil via the pump inlet. This may be performed as required if using petrol which can dry out the vanes inside reducing suction & priming.

Operating Instructions

When using as a siphon pump

- 1 Turn the handle 5 or 6 times. When the liquid begins to flow from the outlet, place handle at a horizontal direction.
- 2 If the liquid stops being transferred flowing, move the handle slightly.
- 3 After use, fix the handle to the indicated point. Then the liquid inside the pump can now flow back into the drum.
- 4 Siphoning will not work when pumping liquid of a high viscosity. The pump will not siphon successfully unless all hose and pump joints are fully tightened up and all connection points are completely airtight.



Caution

Do not use this pump for transferring solvents, strong alkalis or acids as the pumps seals and gaskets are incompatible with aggressive solutions. Contact us for various chemical pump models available.

Trouble Shooting

Trouble	Remedy
Important information for increasing the life of your 501A pump	Please note that while the 501A materials offer excellent compatibility for most oils and fuels, some fuels will "dry out" the internals of the pump causing parts "to stick" and the priming action of the pump reduced. To stop this from happening, and to increase the working life of your pump, we strongly recommend that at the end of each day you lubricate the vanes of the pump by adding a few drops of oil to the internals of the pump via the outlet opening. By lubricating the vanes and then rotating the handle around two or three times at the end of each day or at the end of a production run, you will ensure that the internals of the pump are well lubricated. This practice will also ensure that the next time you go to use the pump the handle will rotate smoothly and easily through its rotation and the pump will prime instantly.
Pump does not pump	Check suction tubes to make sure they are airtight.
Handle is stiff to turn	<ol style="list-style-type: none"> 1. Lubricate with drops of oil. Rinse pump with water or other suitable solvent for chemical being pumped. 2. Open pump body and clean internal parts so they rotate freely. 3. If rotor or vanes are swollen from chemical permeation, they may need to be replaced.



Parts And Drawing Breakdown For The 501A

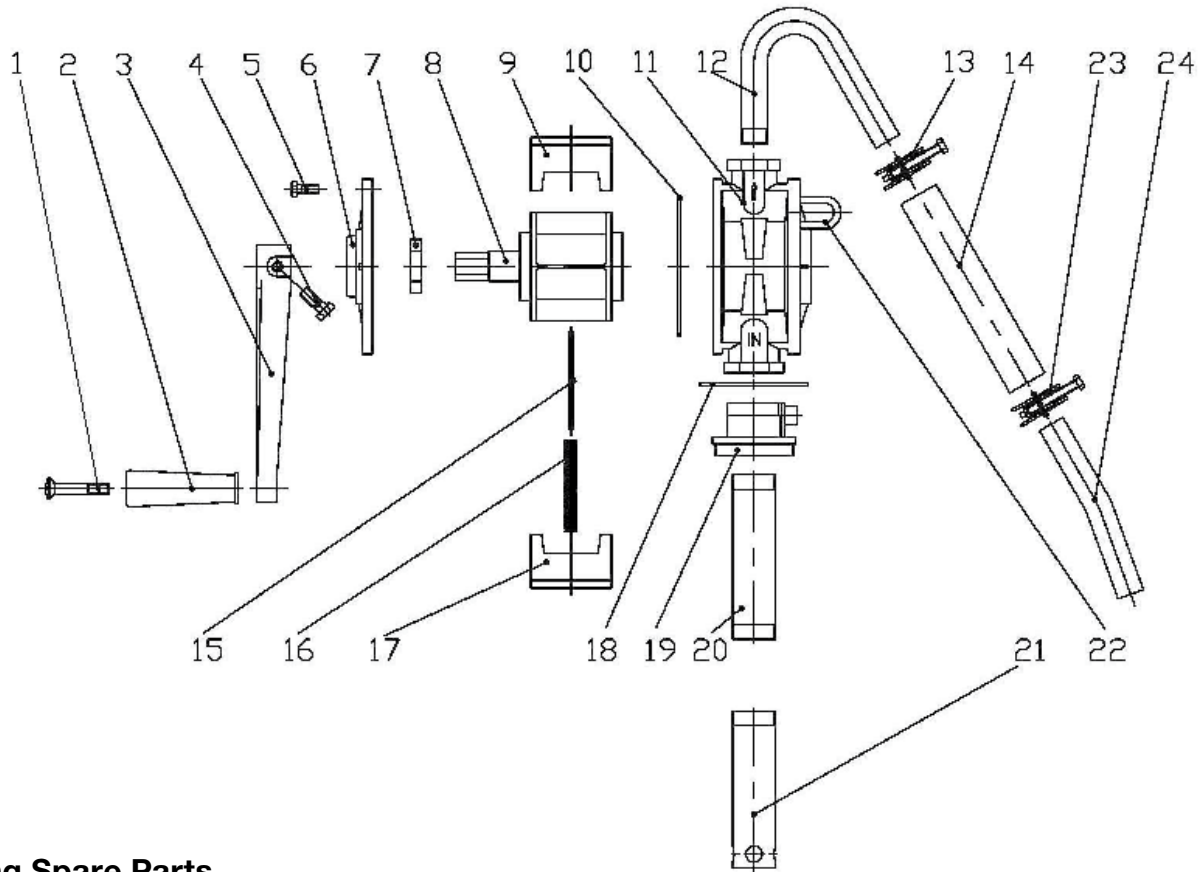

Ordering Spare Parts

Parts List – Part No. 501A

ITEM	PART NO	DESCRIPTION	QTY
1	501A-1	Grip Shaft	1
2	501A-2	Handle	1
3	501A-3	Handle Shaft	1
4	501A-4	Locking Bolt	1
5	501A-5	Locking Bolt	6
6	501A-6	Pump Cover	1
7	501A-7	Oil Seal	1
8	501A-8	Rotor	1
9	501A-9	Vane	1
10	501A-10	O-Ring	1
11	501A-11	Pump Body	1
12	501A-12	Outlet Spout	1
13	501A-13	Hose Clamp	1
14	501A-14	Anti static delivery Hose	1
15	501A-15	Vane Pin	1
16	501A-16	Vane Spring	1
17	501A-17	Vane	1
18	501A-18	Rubber Shroud	1
19	501A-19	Bung Adaptor	1
20	501A-20	Upper Suction Tube	1
21	501A-21	Lower Suction Tube	1
22	501A-22	Spout Holster	1
23	501A-23	Hose Clamp	1
24	501A-24	Delivery Spout	1

NSW/ACT

TEL: (02) 9677 1555
FAX: (02) 9675 1155

QLD/PNG

TEL: (07) 3204 9166
FAX: (07) 3204 1224

VIC/TAS

TEL: (03) 8787 8288
FAX: (03) 8787 8266

WA

TEL: (08) 9302 4199
FAX: (08) 9303 2095

SA/NT

TEL: (08) 8241 7111
FAX: (08) 8241 7011

NZ

TEL: (09) 447 1007
FAX: (09) 447 1008